

# A Zero-Stiffness Elastic Shell Structure

S.D. Guest, E. Kebabze\*

Department of Engineering, University of Cambridge,  
Trumpington Street, Cambridge CB2 1PZ, UK

S. Pellegrino

Graduate Aerospace Laboratories,  
California Institute of Technology,  
Pasadena, CA 91125, USA

May 17, 2010

## Abstract

A remarkable shell structure is described that, due to a particular combination of geometry and initial stress, has zero stiffness for any finite deformation along a twisting path; the shell is in a neutrally stable state of equilibrium. Initially the shell is straight in a longitudinal direction, but has a constant, non-zero curvature in the transverse direction. If residual stresses are induced in the shell by, e.g., plastic deformation, to leave a particular resultant bending moment, then an analytical inextensional model of the shell shows it to have no change in energy along a path of twisted configurations. Real shells become closer to the inextensional idealization as their thickness is decreased; experimental thin-shell models have confirmed the neutrally stable configurations predicted by the inextensional theory. A simple model is described that shows that the resultant bending moment that leads to zero stiffness gives the shell a hidden symmetry, which explains this remarkable property.

## 1 Introduction

A novel zero stiffness structure is described. The structure is a thin shell that is initially straight in a longitudinal direction, but has a uniform, non-zero curvature in the transverse direction. The structure is prestressed, and the interaction of the elastic properties with the prestress is such that the structure can be deformed without any applied load; this is not a local phenomenon — the structure can continue to be deformed in a finite closed

---

\*Currently at BP Exploration, Chertsey Road, Sunbury upon Thames, Middlesex TW16 7LN, UK.

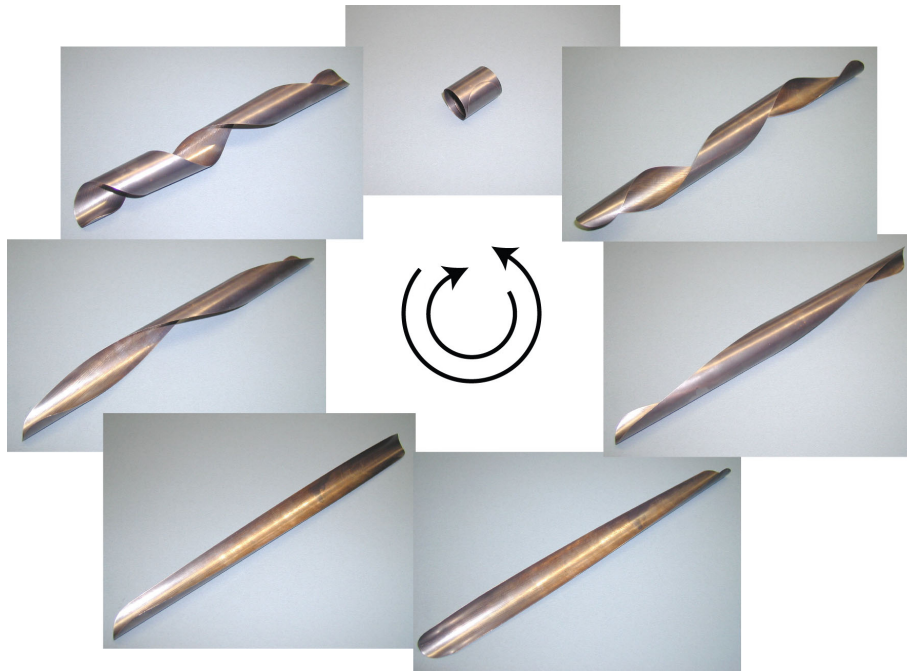

Figure 1: A series of different configurations of the *same* zero-stiffness shell structure. In each configuration, the shell is held in place by no more than the friction with the underlying surface. The shell can be transformed between configurations in both directions, clockwise and anticlockwise. The analytical model in Section 2 predicts that the shell will, in each case, be wrapped around an underlying cylinder (see Figure 3) of constant radius; and it can be seen that this is the case here.

path. Equivalently, the structure is neutrally stable: there is no change in total internal strain energy as the structure is deformed, even though any particular component of strain energy will vary. An experimental model of this structure, made from a sheet of Copper Beryllium of thickness 0.1 mm and width 30 mm is shown in Figure 1.

The ability to deform a structure without load is quite unexpected when initially observed, and is clearly a function of the prestress that the shell carries. Certainly it is well known that the stiffness of structures changes with applied load. Stable structures can become unstable when loaded: a simple example is the buckling of a strut through the application of axial load. At the cusp between stability and instability there may then be a point of neutral stability, where a structure has zero stiffness: to first order, there is no change in load with displacement. However, while typically for buckling phenomena this point of neutral stability/zero stiffness is isolated, it is also possible to engineer systems which, when they buckle, are neutrally

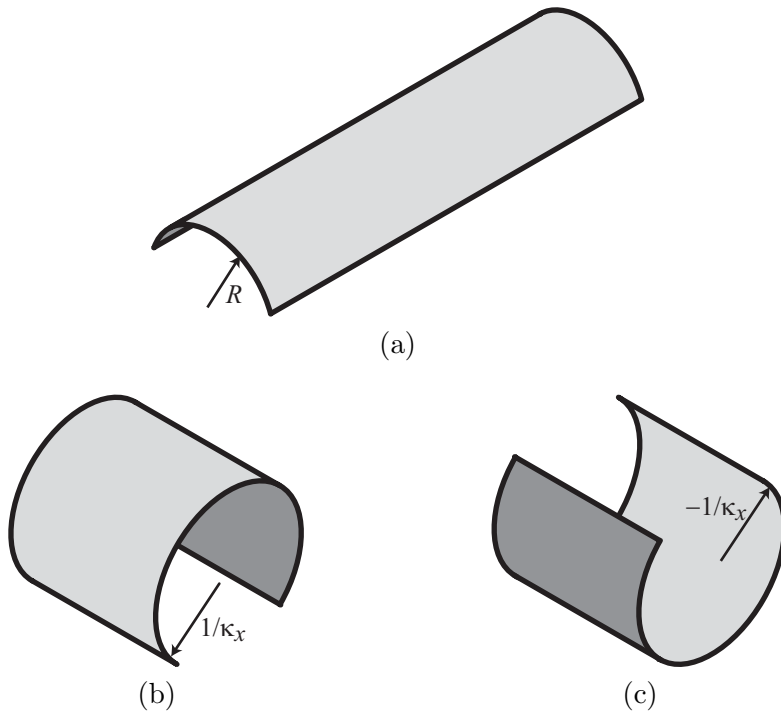

Figure 2: (a) A shell that is straight longitudinally, but curved transversely, with two coiling modes, (b) and (c). A configuration change from (a) to (b) involves *same-sense* bending: the centres of curvature are on the same side of the shell. A configuration change from (a) to (c) involves *opposite-sense bending*: the centres of curvature are on opposite sides of the shell.

stable for large deformations (Tarnai, 2003).

The stiffness of structures also changes through *prestress*, where the structure is loaded against itself. A classical example of this behaviour is provided by tensegrity structures (Calladine, 1978; Guest, 2010), which typically rely on prestress in order to be able to act as structures at all. However, even for tensegrities with rigid compression members, increasing the prestress can reduce the stiffness of some modes of deformation, and for extreme levels of prestress, can also lead to structures with zero stiffness, even for large deformations (Schenk et al., 2007).

The present paper deals with thin shell structures that are straight longitudinally, but uniformly curved in the transverse direction, as shown in Figure 2(a). Shell structures of this type are used in steel tape measures and also as lightweight deployable booms for spacecraft (Rimrott, 1965). The mechanics of such structures has been studied extensively (Mansfield, 1973; Seffen and Pellegrino, 1999), although until recently most studies have focused on structures that are both isotropic and initially unstressed.

Recently, it has become clear that interesting properties, and in particular bistability, can be engendered if these curved thin shell structures are made to be anisotropic (Guest and Pellegrino, 2006), or if the structures are prestressed (Kebadze et al., 2004). If the shells are given the correct set of anisotropic bending properties, e.g., through being manufactured in fibre-reinforced plastic, then the shell can be made bistable so that the second stable state has the *same* sense of bending, as shown in Figure 2(a)&(b). Alternatively, if an isotropic shell is correctly prestressed, then the shell can be made bistable with the second stable state having the *opposite* sense of bending, as shown in Figure 2(a)&(c). In this case, in the initial configuration, the shell is prestressed in bending, so that it wishes to coil up, but this is prevented by the structural depth of the curved shape. Pellegrino (2005) describes a shell that exploits this mode while ensuring that the two states have the same stored strain energy, so that a partially coiled shell can coil and uncoil without change of energy, and is neutrally stable. This is the only previous example of a zero stiffness shell of which we are aware.

The present paper explores the case of an isotropic shell which is prestressed in the opposite sense to that studied in Keadze et al. (2004), so that the prestress favours same-sense bending. It will show that bistability cannot be engendered, but remarkably, for a particular value of prestress, the structure can be left without any torsional stiffness.

## 2 Analytical model

The basic analytical model that we use is essentially identical to that described in Keadze et al. (2004) and Guest and Pellegrino (2006). We make two geometric assumptions: that the shell is inextensional; and that the curvature of the shell is uniform across its mid-surface. The inextensional assumption is valid for thin shells, where the energy required to stretch the shell dwarfs the energy required to bend the shell. A consequence of our assumptions is that we are neglecting boundary effects; for further discussion of this, see Galletly and Guest (2004). The two geometric assumptions together imply that we can consider the shell mid-surface as lying on an underlying cylindrical surface, as shown in Figure 3. The (uniform) curvature of the surface can then be described in terms of two parameters, the curvature of the underlying cylinder  $C$ , and the orientation of the local axes  $(x, y)$  with respect to the axis of the cylinder, defined by an angle  $\theta$ .

The curvature of the shell can thus be described by the curvature vector  $\boldsymbol{\kappa}$

$$\boldsymbol{\kappa} = \begin{bmatrix} \kappa_{xx} \\ \kappa_{yy} \\ 2\kappa_{xy} \end{bmatrix} = \frac{C}{2} \begin{bmatrix} 1 - \cos 2\theta \\ 1 + \cos 2\theta \\ 2 \sin 2\theta \end{bmatrix} \quad (1)$$

where the transformation to the  $x, y$  curvilinear coordinates is obtained

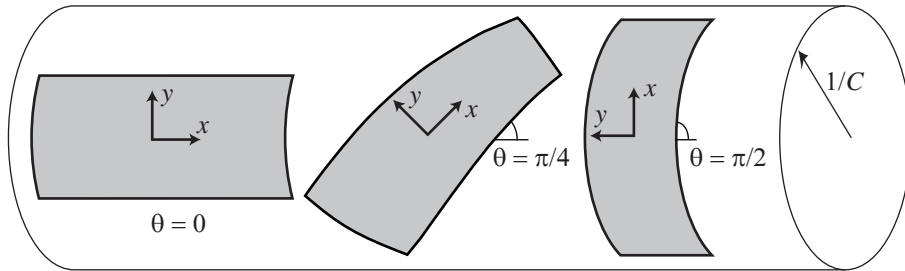

Figure 3: Definition of the geometry of the shell in terms of an underlying cylinder with curvature  $C$ . The angle  $\theta$  specifies the orientation of the shell with respect to the cylinder.

from, e.g., a Mohr's circle construction, as described in Guest and Pellegrino (2006). Note that this assumes the definition  $\kappa_{xy} = -\partial^2 w / dx dy$  for the twisting curvature, as is standard in the plates and shells literature, including Kebabzade et al. (2004), but only half the value commonly used in the composites literature, including Guest and Pellegrino (2006).

We assume an initial configuration for the shell with  $\theta_0 = 0$  and  $C_0 = 1/R$ , so the change in curvature to any other configuration is given by

$$\Delta \boldsymbol{\kappa} = \frac{C}{2} \begin{bmatrix} 1 - \cos 2\theta \\ 1 + \cos 2\theta - \frac{2}{CR} \\ 2 \sin 2\theta \end{bmatrix} \quad (2)$$

We also assume that the shell is prestressed in the initial configuration. As the shell is straight in the  $x$ -direction, it cannot sustain any moment/unit length along the edge normal to the  $y$ -axis, so in the initial configuration  $m_y = m_{xy} = 0$ . However, because of the curvature in the  $y$ -direction, the depth of the cross-section allows a uniform initial moment  $m_x = m$  to be equilibrated by mid-plane forces in the shell, as shown in Figure 4.

In a general configuration we define the moment/unit length carried by the shell as a vector  $\mathbf{m}$ ,

$$\mathbf{m} = \begin{bmatrix} m_x \\ m_y \\ m_{xy} \end{bmatrix} \quad (3)$$

with an initial value,

$$\mathbf{m}_0 = \begin{bmatrix} m \\ 0 \\ 0 \end{bmatrix}. \quad (4)$$

We assume linear-elastic material behaviour, and therefore in a general configuration, the moment will be given by

$$\mathbf{m} = \mathbf{D} \Delta \boldsymbol{\kappa} + \mathbf{m}_0. \quad (5)$$

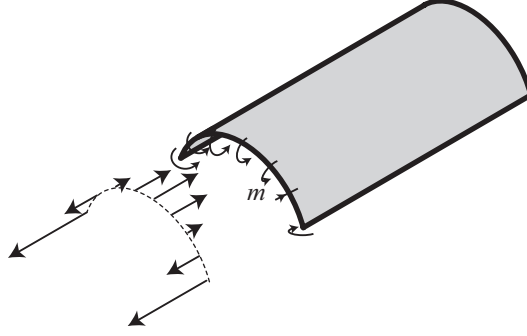

Figure 4: Initial prestress in the shell. The uniform moment/unit length  $m_x = m$  is equilibrated by a distribution of mid-plane forces in the shell. The moment  $m$  is uniform throughout the shell, except for a narrow boundary layer at the free ends.

The bending stiffness matrix  $\mathbf{D}$  is given by

$$\mathbf{D} = D \begin{bmatrix} 1 & \nu & 0 \\ \nu & 1 & 0 \\ 0 & 0 & (1 - \nu)/2 \end{bmatrix} \quad (6)$$

where  $\nu$  is the Poisson's ratio of the material, and  $D$  is the shell bending stiffness, defined in terms of the Young's modulus  $E$ , thickness  $t$  and Poisson's ratio as

$$D = \frac{Et^3}{12(1 - \nu)^2} \quad (7)$$

We define the strain energy  $U$  as the energy stored in the shell per unit area due to its deformation away from the initial configuration, and so

$$U = \frac{1}{2} \Delta \boldsymbol{\kappa}^T \mathbf{D} \Delta \boldsymbol{\kappa} + \Delta \boldsymbol{\kappa}^T \mathbf{m}_0 \quad (8)$$

Finally, we write everything in a non-dimensional form (with a hat  $\hat{\cdot}$ ) in terms of the bending stiffness,  $D$ , and initial radius of curvature  $R$ ,

$$\hat{U} = \frac{UR^2}{D}; \quad \hat{\mathbf{D}} = \frac{\mathbf{D}}{D}; \quad \hat{\boldsymbol{\kappa}} = R\boldsymbol{\kappa}; \quad \hat{\mathbf{m}} = \frac{R}{D}\mathbf{m}; \quad \hat{C} = CR;$$

Kebadze et al. (2004) explored the behaviour of this system when the initial moment  $\hat{m} = mR/D$  is positive, which leads to bistable behaviour. The present paper notes the remarkable behaviour associated with the value

$$\hat{m} = -(1 - \nu) \quad (9)$$

Figure 5 shows the variation of  $\hat{U}$  with  $\hat{C}$  and  $\theta$  for three values of  $\hat{m}$ :  $\hat{m} = 0$ ;  $\hat{m} = -(1 - \nu)$ ; and  $\hat{m} = -2(1 - \nu)$ .

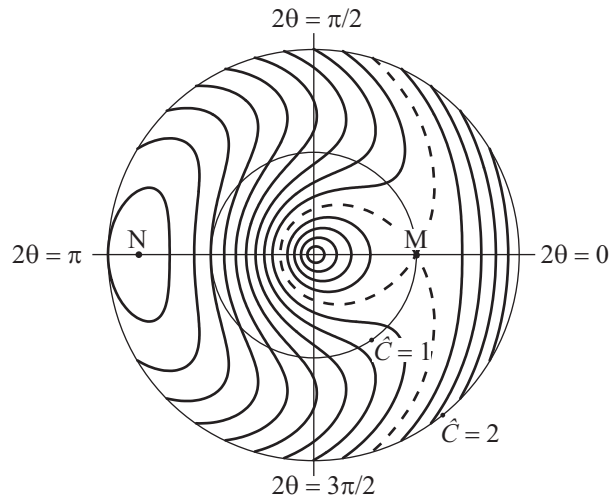
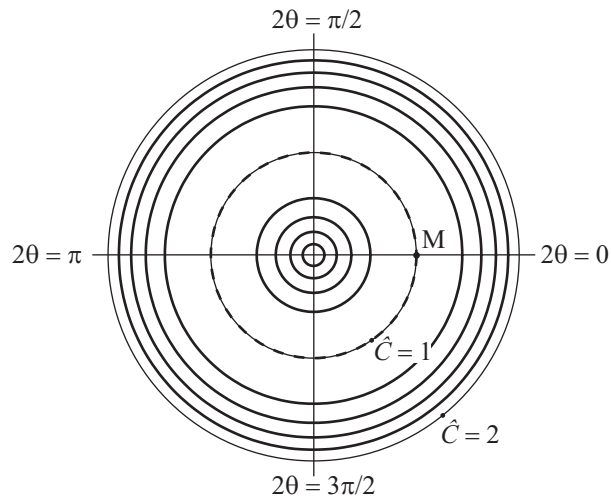
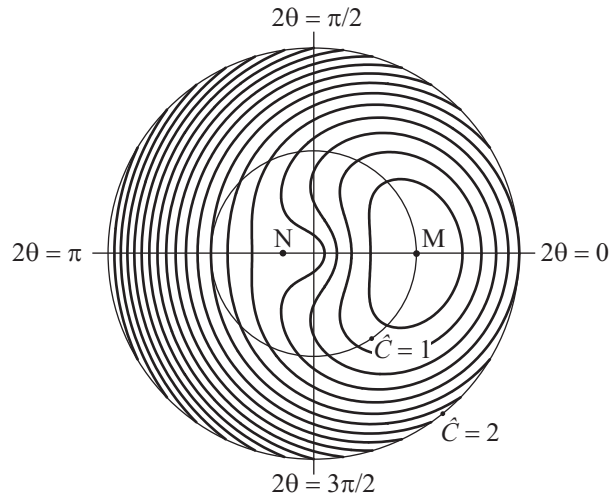

Figure 5: Polar plots of the non-dimensional energy  $\hat{U}$  plotted as a function of  $\hat{C}$  and  $\theta$  for three values of initial moment  $\hat{m}$ . The initial configuration is labelled as M, and  $\hat{U} = 0$  at this point. Contours are plotted for  $\hat{U} = \dots, -0.1, 0, 0.1, \dots$ , with  $\hat{U} = 0$  plotted as a dashed line.

The key plot is Figure 5(b). For  $\hat{m} = -(1 - \nu)$ , there is no change in stored energy  $\hat{U}$  with  $\theta$ . Thus, from the initial configuration, a series of new twisted configurations with the same underlying curvature  $\hat{C} = 1$  are possible, and these are clearly shown in the experimental results shown in Figure 1. The structure is in a state of neutral equilibrium, and has zero stiffness, even for large excursions along this deformation path.

Figures 5(a)&(c) represent the behaviour of the shell for values of  $\hat{m}$  respectively greater or smaller than the critical value of  $-(1 - \nu)$ . Figure 5(a) shows the case where  $\hat{m} = 0$ , and is hence identical to the isotropic plot in Guest and Pellegrino (2006). There are two equilibrium configurations, marked M and N: M is the stable initial configuration, and N is an unstable coiled configuration, where  $\theta = \pi/2$ . In fact, for any value of  $\hat{m}$  in the range  $0 \geq \hat{m} > -(1 - \nu)$  similar behaviour is observed, with a stable initial configuration, and an unstable coiled configuration.

Figure 5(c) shows the case where  $\hat{m}$  is twice the critical value of  $-(1 - \nu)$ . Again there are two equilibrium configurations, marked M and N: M is the initial configuration, which is now unstable, and N is a coiled configuration with  $\theta = \pi/2$ , which is now stable. In fact, for any value of  $\hat{m} < -(1 - \nu)$  similar behaviour is observed, with an unstable initial configuration, and a stable coiled configuration. The energy  $\hat{U}$  is negative at N, but this is simply a consequence of arbitrarily setting  $\hat{U} = 0$  at the original configuration M.

Note that in each of the plots, there appears to be a maximum in  $\hat{U}$  at  $\hat{C} = 0$ , but this is simply an artefact of the way the data is plotted:  $\hat{U}$  will continue to increase for  $\hat{C} < 0$ , but this portion of the data is not plotted in the present paper, as no interesting behaviour is observed in this regime (unlike Kebabze et al. (2004), where additional stable states are found with  $\hat{C} < 0$  for  $\hat{m}$  positive).

### 3 Experimental results

Experimental verification of the zero stiffness behaviour was obtained through models made from a thin sheet of Copper Beryllium (CuBe). The basic manufacturing protocol was as described in Kebabze et al. (2004). The shells were formed in a curved initial state from annealed CuBe with  $t = 0.1$  mm and a width 30 mm, which were then age-hardened to give a stress-free curved shell.

The prestress moment was imposed by passing the unstressed shell through a set of rollers, which leads to a residual moment  $m$  through the mechanism described in Kebabze et al. (2004). Although Section 2 gives a precise value of  $m$  for zero stiffness, it is actually difficult to predict the rolling parameters that will give this value of  $m$ , as this depends on the precise strain-hardening characteristics of the CuBe as it yields. Thus, in practice we proceeded by trial and error to fine-tune the rolling process to give shells that had no tor-



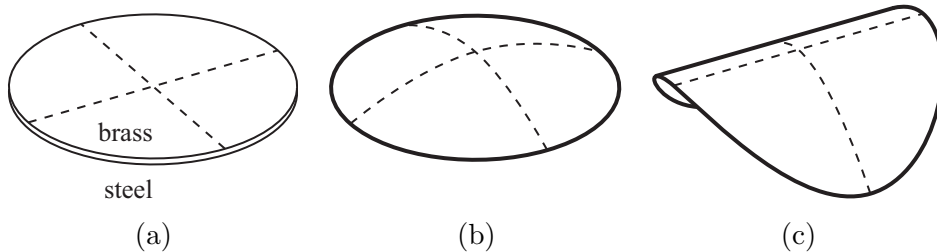

Figure 6: A conceptual model of the formation of a zero-stiffness shell from a bimetallic disk. As the disk is heated from (a), it will initially form a domed structure, (b). After further heating, the bending response will bifurcate and become non-isotropic; and in the limit the structure will become cylindrical, (c). The principal directions of bending in (c) are arbitrary — any other choice of bending direction would lead to a twisted form of the structure the same stored internal energy.

sional stiffness. The final result of this process is shown in Figure 1, where a series of configurations of the same shell is shown, each with an underlying curvature  $C \approx 1/12.5$  mm. In each configuration, the shell is only held in place by friction with the underlying surface. We have not attempted any detailed experimental measurements on these models.

## 4 Conceptual disk model

This section describes a simple conceptual model that has two aims: firstly it will reveal a ‘hidden’ symmetry that provides an explanation for the particular value of prestress moment  $m$  that provides zero stiffness; and secondly, it describes a zero stiffness shell structure that doesn’t require an assumption that the shell is so thin that it can be considered to be inextensional.

Consider a thin circular bimetallic (e.g., brass and steel) flat disk, as shown in Figure 6(a). As the disk is heated from its initial flat stress-free state, the brass will want to expand more than the steel, and if the disk is to remain flat, this will lead to a uniform residual moment in the shell. In practise, the disk will dome slightly, as shown in Figure 6(b), but to do this the surface changes its Gaussian curvature, which requires in-plane stretching (Calladine, 1983). At some point (which depends on the thickness of the shell) a bifurcation will take place, following which the curvature will no longer be uniform in all directions: in some arbitrary principal direction the curvature will decrease, while the curvature will increase in the perpendicular direction. As heating is further increased, the disk will approach a cylindrical configuration, as shown in Figure 6(c); this process is described in more detail by Freund (2000), and Seffen and McMahon (2007).

It is clear that the process of heating a bimetallic disk must lead to a zero-stiffness shell at any point after the disk has bifurcated. The bifurcation takes place about an arbitrary axis; and whichever axis is chosen the stored strain energy will be the same. Deforming the shell on the continuous path through states with varying axes of bifurcation will not change the stored energy, and hence it can be concluded that the path is neutrally stable. We shall see that in the extreme case of a thin shell with no in-plane deformation, this will reproduce the mode described in Section 2; but the bifurcated bimetallic disk does not require any assumption about being thin, or about boundary conditions, to have zero stiffness.

For the assumption of a thin inextensional shell, the bimetallic disk model can be used to calculate the critical value of prestress moment found in Section 2. Consider a preliminary state of the disk where the disk has been heated, but is held flat. In this state, there will be a uniform (-ve) moment due to the temperature change,  $m_t$ , but no curvature:

$$\mathbf{m}_i = \begin{bmatrix} m_t \\ m_t \\ 0 \end{bmatrix} \quad \boldsymbol{\kappa}_i = \begin{bmatrix} 0 \\ 0 \\ 0 \end{bmatrix} \quad (10)$$

Consider now that the disk is released, and is allowed to increase its curvature in the  $y$ -direction until the moment  $m_y$  becomes zero, at which point it has reached the initial state  $(\mathbf{m}_0, \boldsymbol{\kappa}_0)$  considered in Section 2. As the change from the preliminary to the initial state is elastic, we can write

$$\mathbf{m}_0 = \mathbf{D}(\boldsymbol{\kappa}_0 - \boldsymbol{\kappa}_i) + \mathbf{m}_i \quad (11)$$

and hence

$$\begin{bmatrix} m \\ 0 \\ 0 \end{bmatrix} = D \begin{bmatrix} 1 & \nu & 0 \\ \nu & 1 & 0 \\ 0 & 0 & (1-\nu)/2 \end{bmatrix} \begin{bmatrix} 0 \\ 1/R \\ 0 \end{bmatrix} + \begin{bmatrix} m_t \\ m_t \\ 0 \end{bmatrix}. \quad (12)$$

To satisfy this equation in the  $y$ -direction, we must have

$$m_t = -\frac{D}{R} \quad (13)$$

and hence

$$m = \frac{D\nu}{R} - \frac{D}{R}. \quad (14)$$

Thus, the residual prestress moment, written in non-dimensional form,

$$\hat{m} = \frac{mR}{D} = -(1-\nu) \quad (15)$$

is exactly the critical moment identified in Section 2.

## 5 Conclusion

The disk model presented in Section 4 has shown that the zero stiffness mode identified in Section 2 can be explained simply by consideration of a hidden symmetry of the shell structure: if the structure is flattened, then the resultant moment in the shell doesn't vary with direction, and bending about any axis is equally preferable. There may be minor effects associated with boundary conditions, but: (i) these didn't have a noticeable effect on the experimental structures that we manufactured; and (ii) they will certainly not be present for a circular shell structure.

## Acknowledgements

This research was sponsored by the EPSRC (research grant GR/M72852/01) and supported by Rolatube Technology Ltd. SDG acknowledges support from the Leverhulme Trust.

## References

- Calladine, C. R. (1978). Buckminster Fuller's "Tensegrity" structures and Clerk Maxwell's rules for the construction of stiff frames. *International Journal of Solids and Structures*, 14:161–172.
- Calladine, C. R. (1983). *Theory of Shell Structures*. Cambridge University Press.
- Freund, L. B. (2000). Substrate curvature due to thin film mismatch strain in the nonlinear deformation range. *Journal of the Mechanics and Physics of Solids*, 48(6–7):1159–1174.
- Galletly, D. A. and Guest, S. D. (2004). Bistable composite slit tubes II: a shell model. *International Journal of Solids and Structures*, 41(16–17):4503–4516.
- Guest, S. D. (2010). The stiffness of tensegrity structures. Submitted for publication to the IMA Journal of Applied Mathematics.
- Guest, S. D. and Pellegrino, S. (2006). Analytical models for bistable cylindrical shells. *Proceedings of the Royal Society: Mathematical, Physical & Engineering Sciences*, 462(2067):839–854.
- Kebadze, E., Guest, S. D., and Pellegrino, S. (2004). Bistable prestressed shell structures. *International Journal of Solids and Structures*, 41(11–12):2801–2820.

- Mansfield, E. H. (1973). Large-deflexion torsion and flexure of initially curved strips. *Proceedings of the Royal Society of London. Series A, Mathematical and Physical Sciences*, 334(1598):279–298.
- Pellegrino, S. (2005). Bistable shell structures. In *Proceedings, 46th AIAA/ASME/ASCE/AHS/ASC Structures, Structural Dynamics & Materials Conference, 18–21 April 2005, Austin, Texas*.
- Rimrott, F. P. J. (1965). Storable tubular extendible member: a unique machine element. *Machine Design*, 37:156–163.
- Schenk, M., Guest, S. D., and Herder, J. L. (2007). Zero stiffness tensegrity structures. *International Journal of Solids and Structures*, 44:6569–6583.
- Seffen, K. A. and McMahon, R. A. (2007). Heating of a uniform wafer disk. *International Journal of Mechanical Sciences*, 49(2):230–238.
- Seffen, K. A. and Pellegrino, S. (1999). Deployment dynamics of tape springs. *Proceedings of the Royal Society: Mathematical, Physical and Engineering Sciences*, 455(1983):1003–1048.
- Tarnai, T. (2003). Zero stiffness elastic structures. *International Journal of Mechanical Sciences*, 45(3):425–431.